

# MONITORING OPTICAL DATA CONNECTION BETWEEN PROTECTED ROOMS IN SMART CITIES

Gábor Bréda\*

Óbuda University, Doctoral School on Safety and Security Sciences  
Budapest, Hungary

DOI: 10.7906/indecs.17.3.3  
Regular article

*Received:* 7 February 2019.  
*Accepted:* 31 August 2019.

## ABSTRACT

The infrastructures of Smart Cities presuppose the existence of a basic IT data transmission network. This is also true for point-to-point connections between protected spaces in potentially different locations. The establishment of a stable IT connection is an essential element in the development of information infrastructures. Transmission bandwidth is a basic parameter to show the functionality and usability an IT system. As a result of advances in fibre-optic data technology, fibre-optic data connectivity solutions have now become standard tools, and due to their features, other technologies used for long distance connections have been almost completely eliminated by this technology. Continuous operation of fibre-optic connectivity has become vital to the operation of Smart City devices, as well as to the continued stable operation of critical infrastructures and protected spaces. Thus, the failure of an optical fibre requires immediate troubleshooting and corrective action from the operator. The scope of this research includes the basic methods of fault detection with regard to optical fibres, from simple methods to testing with the Optical Time Domain Reflectometer as a basic and important measurement method in the operation of optical data communication networks.

## KEY WORDS

optical fibre, optical fibre monitoring system, protected room, optical time-domain reflectometer

## CLASSIFICATION

JEL: L63, L94, L96

PACS: 84.40.Ua, 84.40.

\*Corresponding author, η: [bredagabi@freemail.hu](mailto:bredagabi@freemail.hu); -;  
H – 1428 Budapest, Pf.:31, Hungary\*

## INTRODUCTION

Regarding the info-communication transmission channels of Smart Cities of the 21<sup>st</sup> century, the most important trunking solution has now become fibre. This technology is a great tool not only for a leased line channel, due to its transmission bandwidth and ease of deployment, but it also allows the monitoring of continuous operation. Because of this feature, it is also suitable for realising point-to-point secure communication as a reliable physical channel for data transmission between protected rooms. By operating a thread monitoring system, it is possible to accurately determine the fault location in the event of a longitudinal parameter change or error. In addition to the implementation of telecommunication systems, the fibre-optic plant is also capable of ensuring protected communications depending on the signal encryption, as well as serving as a communication link for automated field systems having their own standards. This technology can be well utilised as the physical layer of the communication channel for information security-protected rooms, because by using cryptographic tools and running a continuous thread monitoring system, the point-to-point communication line can also be controlled for its physical parameters. Thread monitoring guarantees immediate detection and fault location of transmission channel malfunctions for long-distance connections of industrial automation. Another advantage of optical fibres is their insensitivity-free operation and ease of installation. A disadvantage is that only special target devices can implement continuity bonds. The purpose of this research is to systematise the theoretical solutions needed for detecting serial errors in optical fibres, and to review the basic application of a fibre monitoring tool.

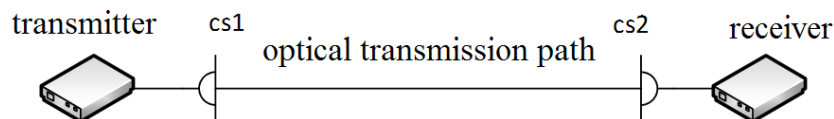
**Thesis 1:** Today's primary trunked data transmission channel is the optical fibre.

**Thesis 2:** By implementing optical fibre monitoring, a safer and faster fault location detection can be achieved in case of serial errors.

**Thesis 3:** Fibre-optic communication is the safest way to secure point-to-point communication between protected rooms.

## OPTICAL FIBRE CONNECTION AND ATTENUATION MEASUREMENTS ON THE OPTICAL FIBRE

Optical fibres can be classified according to various parameters which are very important in the design, operation and fault diagnosis of a system. In an optical network, there is always a transmitter device which is connected to the light transmission medium by means of at least one connector; in this case, the optical fibre, and then again, through a connector to a receiving unit, which receives the light pulses emitted by the transmitter, Figure 1.



**Figure 1.** The most basic connection model.

This is the minimal set-up for a single fibre connection. However, a light connection is only established if the transmitter and receiver are capable of transmitting light signals with appropriate line attenuation. One of the most important parameters of a fibre is attenuation, since this value determines the maximum distance that can be travelled between the transmitter and the receiver without a repeater regenerator. Light suffers energy loss until it reaches the transmitter and the receiver. The attenuation rate is 10 times the 10-based

logarithm of the quotient of power transmitted at the transmitter side and the receiver-side output power of the end of the “1” optical transmission path, according to formula (1).

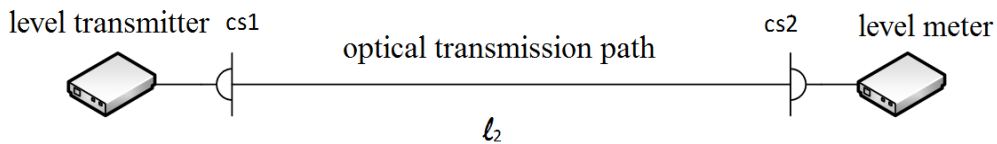
$$\alpha = 10 \cdot \log \frac{P_{be}}{P_{ki}}, \text{ [dB]}. \tag{1}$$

Since the fibre-optic network is a distributed parameter network, the equation can also be given per kilometre using formula (2) [1, 2, 11, 12].

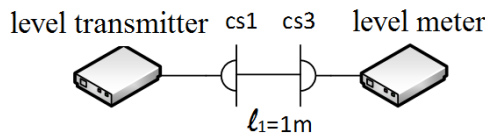
$$\alpha = \frac{10}{l} \log \frac{P_{be}}{P_{ki}}, \left[ \frac{\text{dB}}{\text{km}} \right]. \tag{2}$$

### CUTBACK METHOD

For the cutback method, the first step is to make a measurement at the end of the optical fibre with a level meter in an assembly that is shown in Figure 2. The amount of light output from the level transmitter must be measured. Then, the optic fibre must be cut one meter from the transmitter, and have a connector attached to its end, as shown in Figure 3, and the transmitter signal power has to be measured again [13].



**Figure 2.** Measurement of fibre attenuation for the cutback method.



**Figure 3.** Measurement of fibre attenuation in case of a cut fibre.

From the results of the measurements, the attenuation per kilometre can be determined using formula (3).

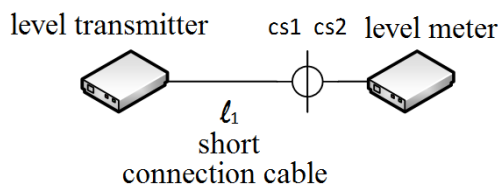
$$\alpha = \frac{1}{l_2 - l_1} \cdot 10 \log \frac{P_{cs3}}{P_{cs2}}, \left[ \frac{\text{dB}}{\text{km}} \right]. \tag{3}$$

### INSERTION LOSS METHOD

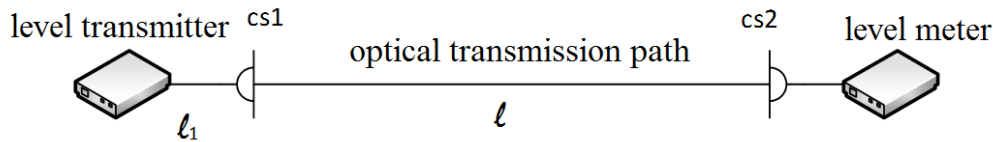
The insertion method is theoretically very similar to the cutback method, but first the power of the leveller on a short thread is measured, then the level transmitter, as shown in Figure 4, and finally the level again at the fibre end. This is shown in Figure 5 [3-5, 14].

The fibre attenuation can be calculated using formula (4).

$$\alpha = \frac{1}{l - l_1} \cdot 10 \log \frac{P_{cs1}}{P_{cs2}}, \left[ \frac{\text{dB}}{\text{km}} \right] \tag{4}$$



**Figure 4.** First measurement set-up for the Insertion Loss Method.



**Figure 5.** Second measurement set-up for the Insertion Loss Method.

Comparing the two measurements, the latter proves to be more appropriate, even during a plant measurement, since in this case the fibre to be measured does not have to be cut. When constructing optical cable networks, an attenuation test report must always be prepared for the future. In the event of an error, this is the first parameter to check. The simplicity of the measurement is a great advantage, while, the fact that it requires intervention at both ends of the fibre can be a disadvantage. In practice, it is advisable to connect the level transmitter and the level receiver to each other at the beginning of the measurement using a short measuring cable, and to set the reference levels relative to each other [6-10].

## BACKSCATTER METHOD

Backscatter measurement has made significant advances in the determination of optical fibre parameters. This measurement principle is most significant, as modern optical cable management systems use this method to determine parameters and errors.

The method is based on Rayleigh scattering. A scattering occurs at the error location with virtually every change in the fibre parameters, which spreads power backward through the fibre. Scattering can be detected with a proper metering system. The attenuation or attenuations can be rendered visual over the entire length of the fibre over time.

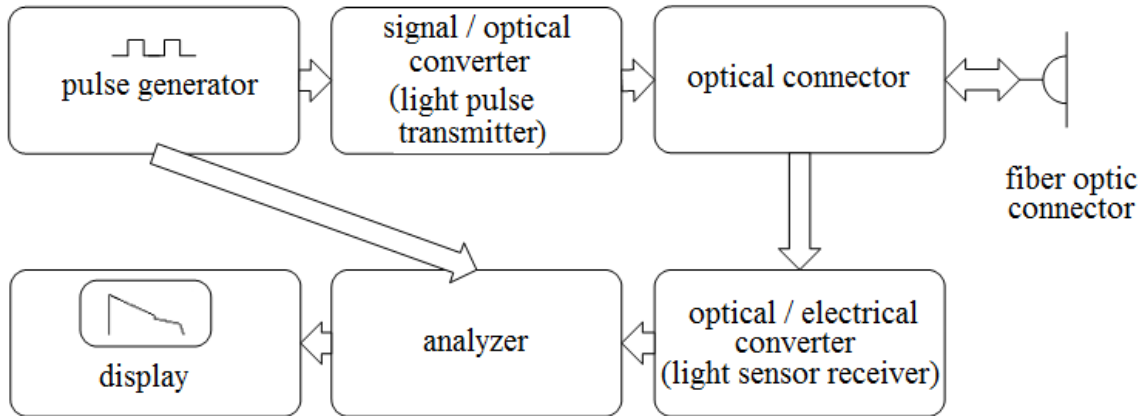
The instruments suitable for this measurement technique are called Optical Time Domain Reflectometers (OTDRs). The measurement can be used mainly for the following purposes:

- determination of defective locations and their distances on optic fibres,
- measuring the attenuation of the connections,
- to measure the specific attenuation of optical fibres

By monitoring the backscatter, all significant features required for installation and operation can be determined. Furthermore, compared to the previous two attenuation measurements, in this case, the measurement can be done from one side, providing significant advantages for quick measurement.

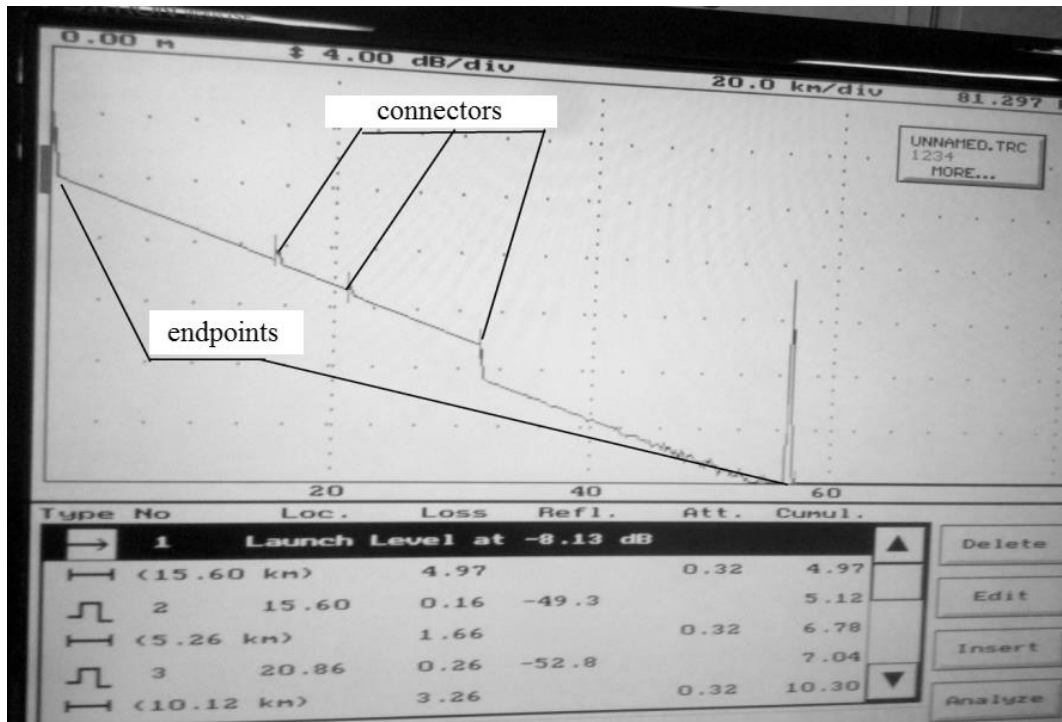
The principle of the measurement is as follows: A narrow light pulse is applied to the fibre input. The light pulse propagates through the fibre, while the light is reflected to the input from every continuity defect and the end of the fibre. At the fibre input, where the light pulse was applied, we now connect a light-sensitive photodiode. From the backscattering signals that the photodiode can detect, we can render a visual representation plotted against time, as we know the speed of light propagating through the fibre [15, 16, 30].

A general block diagram of an OTDR instrument is shown in Figure 6.



**Figure 6.** Block diagram of the internal structure of the OTDR.

If the fibre is constant throughout its length, the curve shows a steadily decreasing pattern. Jump peaks appear at the end and beginning of the fibre, as the refractive index of the fibre changes abruptly at these locations. In the inhomogeneous connection and bonding locations, where the kilometre-specific attenuation is different from the average, steps are forming on the curve. These are called reflective points. An example of a practical measurement by the OTDR instrument during the research is shown in Figure 7.



**Figure 7.** Screenshot of an OTDR measurement.

The length of the fibre can be determined from the start-end-start run time of the light pulses in the fibre. By measuring the time between peaks, the length of the fibre between the peaks can be calculated. The distance to propagation velocity can be calculated using the time differences and the refractive index using the following formula (5).

$$l = \Delta t \frac{c}{n}, \quad (5)$$

where  $l$  is the fibre length,  $c = 300\,000$  km/s;  $n$  is the refractive index and  $\Delta t$  refractive index between peaks. The length attenuation can be read from the back-scattered length-performance diagram. This image is shown in Figure 7.

Figure 8 shows the basic fibre length attenuation measurement, which can also be calculated using formula (6), where  $l_1$  and  $l_2$  are the lengths of the measuring and the measured fibres, and  $P_{l_1}$  and  $P_{l_2}$  are the power levels of the light pulses generated and received [17, 18].

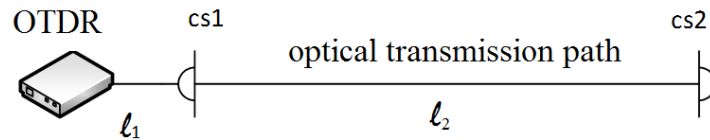


Figure 8. OTDR measurement.

$$\alpha = \frac{1}{2(l_2 - l_1)} \cdot 10 \log \frac{P_{l_1}}{P_{l_2}}. \quad (6)$$

### OTDR MONITORING OF OPTICAL TIME-DOMAIN REFLECTOMETER

In the course of the research, considering the state-of-the-art OTDR measurement technology, it became evident that there is a solution which allows the in-service monitoring of optical fibres. Such solutions include:

- Dark fibre monitoring when using WDM technology,
- Out-of-band monitoring,
- In-band monitoring,
- Broadband monitor port measurement

With the advancement of optical telecommunication devices, light sources with very narrow wavelengths were developed. These are typically capable of radiating the same wavelength with high stability to achieve a small chromatic dispersion. Later, it became possible to create multiple data transmission channels on an optical fibre by applying appropriate wavelength filters, thus significantly increasing the bandwidth. This is called WDM (Wavelength Division Multiplex) technology. Within this technology, the CWDM (Coarse Wavelength Division Multiplex) and DWDM (Dense Wavelength Division Multiplex) solutions are, in principle, the same, but differ in their wavelengths used for telecommunications. With CWDM, the channels are farther apart than with DWDM. The filters used to separate the wavelengths of the technology are called WDM filters. Figure 9 below illustrates three wavelengths for transmitting multiple wavelengths over a single optical fibre [27, 30].

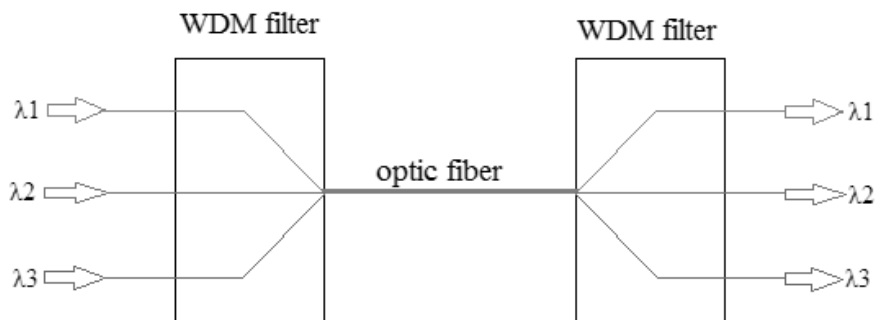
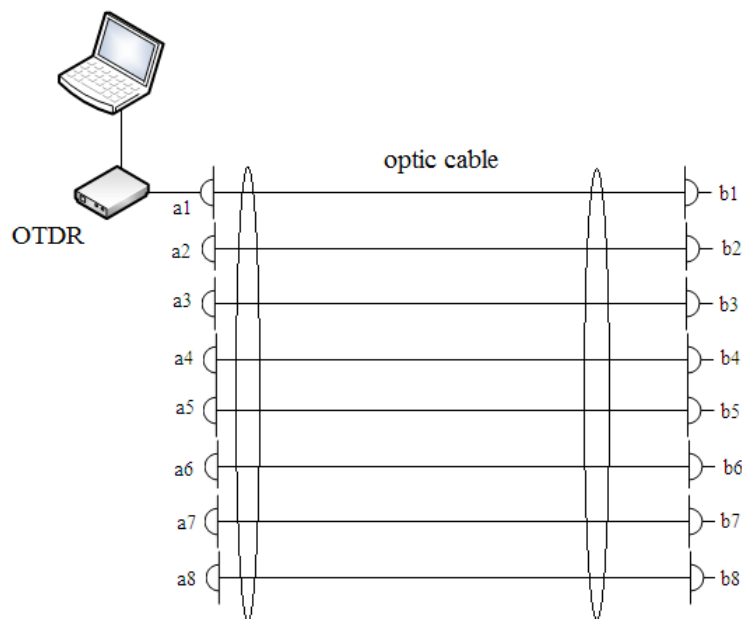


Figure 9. Tri-band WDM filter.

## DARK FIBRE MONITORING

In the case of dark fibre monitoring, a backup fibre of a fibre-optic cable that is not used in telecommunication, or an unused fibre is measured with an OTDR instrument. This measurement provides accurate information on the continuity of the cable and changes in the assumed ageing and attenuation processes. There is no need for expensive filtering and coupling units, but one disadvantage is that it does not give a true picture of the state of the optical fibre that is involved in data transmission, which may be relevant. Of course, this is not a bad solution, since the parameters of the running fibre in a cable are the same and the monitoring of a single fibre within a cable provides about 98% security during business continuity checks. In a single cable, monitoring two strands means 99% security and monitoring three strands means 99,8% security. The implementation should consider the cost of the effort and the desired security.

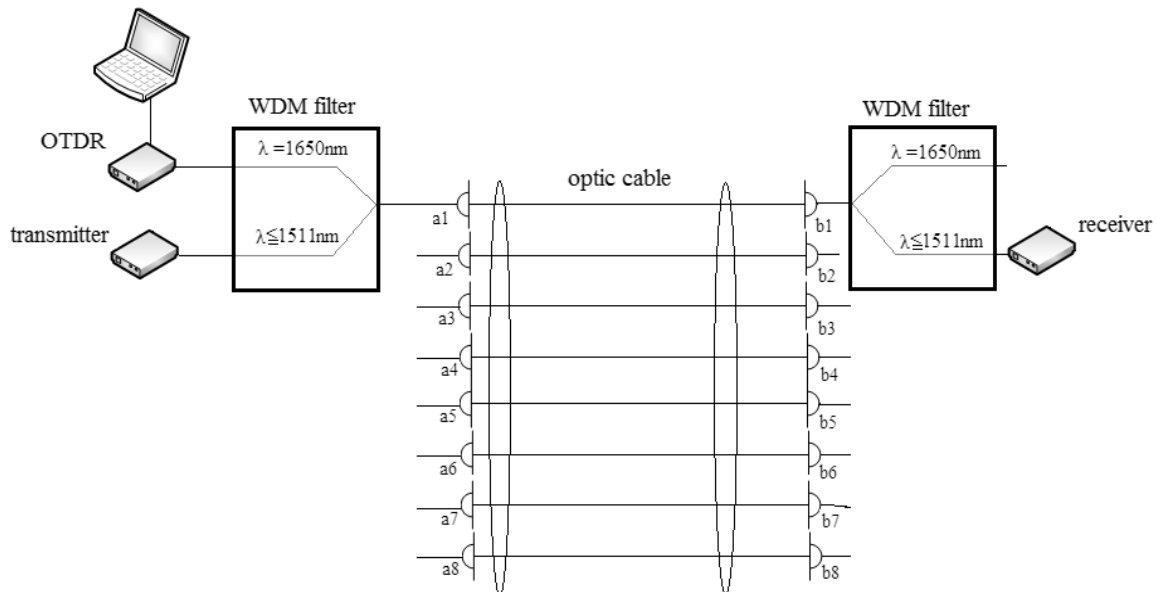
The typical wavelength of the technology is the same as the standard wavelengths of 1310 nm and 1550 nm used in telecommunication. By using 1550 nm, the greatest possible measuring distance is achieved, because at this wavelength the attenuation of the optical fibres is the smallest. It can be implemented with an existing cable network, provided that it has an unused optic fibre. A simple schematic of the technology is shown in Figure 10.



**Figure 10.** Simplified model of the dark fibre monitoring.

## OUT-OF-BAND MONITORING

Out-of-band measurement is based on the principle of transmitting measurement signals to the 1650 nm band in the optical conductor fibre, over the last CDWM 1611nm wavelength channel, and displaying the reflected value on the OTDR display (Figure 11). Wavelength is more sensitive to attenuation originating from fractures and bends. The implementation of this technique requires filter units (WDM), so it is more expensive than the previous solution. A drawback of this technique is that if there are multiple branches in an optical fibre, the exact scattering and the backscattering resulting from the connection of the following elements cannot be well distinguished. It is advisable to implement it before installing the cable network. This method can provide 100% monitoring over the optical fibre involved in telecommunications [26].



**Figure 11.** Simplified model of the out-of-band OTDR monitoring.

## IN-BAND MONITORING

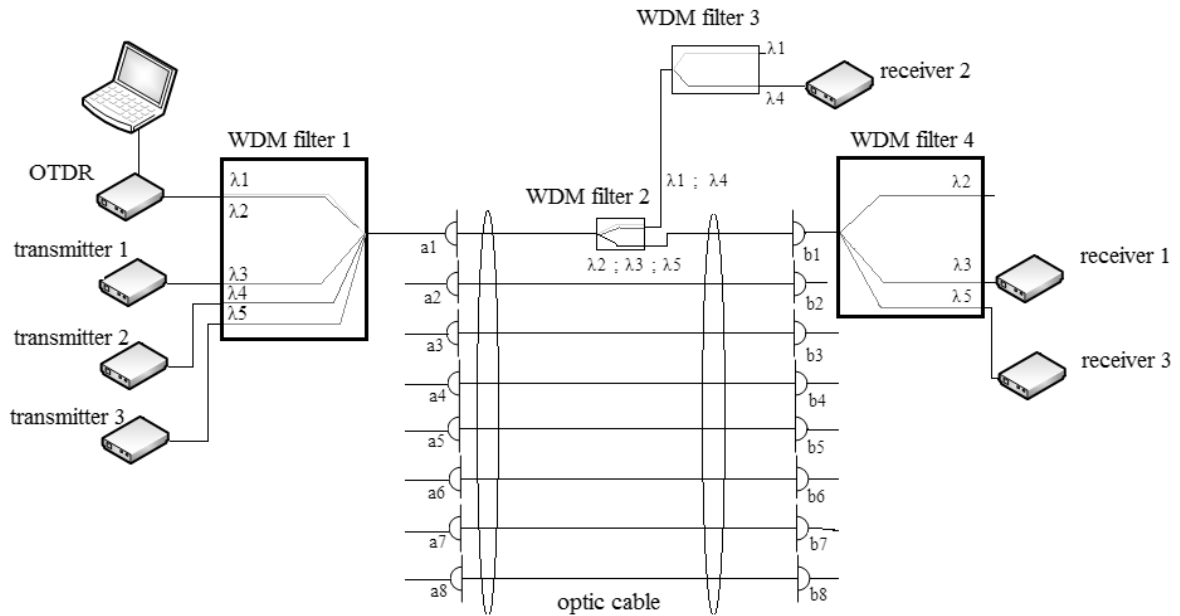
The implementation of this method is similar to the out-of-band method, but this technique uses one or more of the data transmission wavelengths, depending on the implementation. Figure 12 is a conceptual diagram of the monitorability of a branched optical fibre. The figure shows that there are 5 different  $\lambda$  wavelengths added to the cable using a “WDM filter 1”. The different wavelengths are marked with different colours for the sake of illustration:  $\lambda_1$  pink,  $\lambda_2$  blue,  $\lambda_3$  red,  $\lambda_4$  green,  $\lambda_5$  orange.  $\lambda_1$  and  $\lambda_2$  are the wavelengths of the OTDR, while  $\lambda_3$ ,  $\lambda_4$ ,  $\lambda_5$  are the wavelengths of the data transmission. If there is a branch in the light guide, which is referred to as “WDM filter 2” in this figure, the branches can be separated by the proper selection of wavelengths and the application of the appropriate WDM filter. As shown in the figure, following the upper branch of the “WDM filter 2”,  $\lambda_1$  and  $\lambda_4$  (of which  $\lambda_1$  marks the OTDR monitor and  $\lambda_4$  is the data carrier) are passing through. Following the lower branch,  $\lambda_2$ ,  $\lambda_3$ ,  $\lambda_5$  are passing through ( $\lambda_2$  is the OTDR monitor;  $\lambda_3$  and  $\lambda_5$  are the data carriers).

The filters called “WDM filter 3” and “WDM filter 4” separate the appropriate wavelengths for the terminals so that the signals used for data transmission and monitoring do not interfere.

By switching between the  $\lambda_1$  and  $\lambda_2$  wavelengths of the OTDR instrument, the parameters of the given section can be examined. In case of the  $\lambda_1$  OTDR test signal, the line “WDM filter 1” – “WDM filter 2” – “WDM filter 3” can be monitored. In case of the  $\lambda_2$  OTDR test signal the monitoring of the line “WDM filter 1” – “WDM filter 2” – “WDM filter 4” can be ensured.

This example illustrates that multiple optical wavelength signals can be transmitted on an optical fibre. A disadvantage is that the wavelengths used for the measurement cannot be used for data transmission. However, branched optical fibre monitoring can be implemented by changing the OTDR output wavelengths. The measurement system can be installed even in networks with built-in WDM filters. The transmission wavelengths need to be taken into account, and a narrow bandwidth optical signal is required [26].

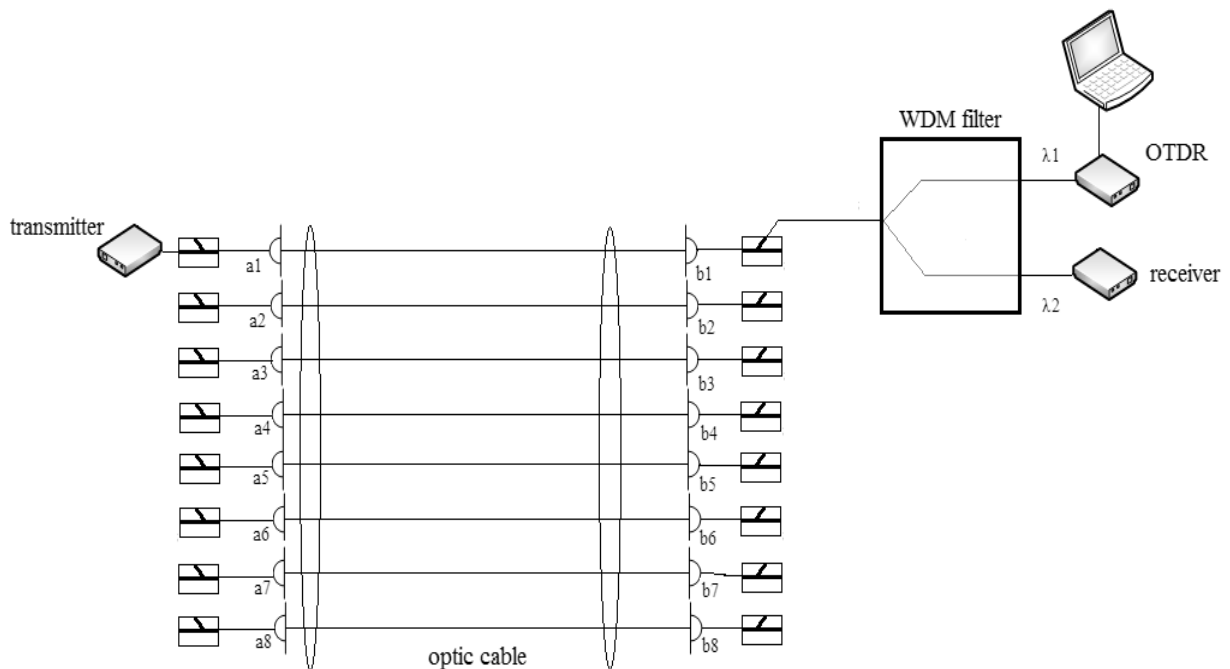




**Figure 12.** Simplified conceptual model of the in-band OTDR monitoring.

### MEASUREMENT VIA BROADBAND BRANCH-LINE COUPLER

At the endpoints of optical networks, full-band and wide-band junctions are used to monitor port traffic (Fig 13). The input and reception of a measurement signal on this device allow the implementation of the OTDR measurement. The measurement signal entered here is also sent and received using a separator (WDM) filter, considering that the wavelength of the measurement signal does not coincide with the wavelength of the data transmission signal. From an implementation point of view, the input signal is fed to the receiving side of the data transmission to avoid interference.

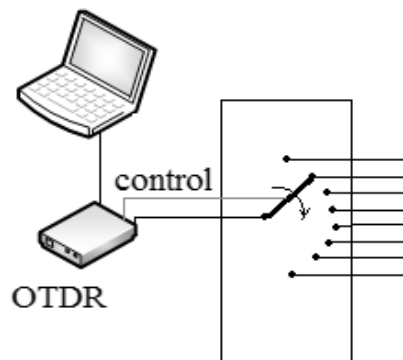


**Figure 13.** Conceptual model of an OTDR monitor installed into a branched network.

## USING AN OPTICAL SWITCH TO EXTEND FIBRE MONITORING

In case of the above examples, the OTDR fibre monitoring was tested on single fibres. However, with full control, each fibre would require its own OTDR instrument. This costly solution can, however, be circumvented by the use of a fibre switching device, without which these advanced fibre management solutions could not be implemented.

The Optical Test Access Unit (OTAU), which operates on the principle of a multiplexer, is an OTDR-controlled fibre switching device that couples the instrument providing the measurement signal to the fibre to be monitored. With the help of appropriate software control, the fibres are switched on, and the continuous measurement is ensured by repeated monitoring. Figure 14 illustrates the operation of the optical switch. The desired OTDR input signals can be set for the channels and a reference value can be recorded during installation, with regards to the measured values and diagrams. If the unit detects an error relative to the reference, it will immediately generate an alarm. In case of this technique, the way fibres queue up to be examined depends on the frequency of switching. The shortest amount of time while a problem could be detected is equal to the amount of time the same fibre is tested again [29].



**Figure 14.** Conceptual model of an optical switch.

Further improvements point to the increase of the speed of error detection. Accordingly, continuous power measurement is performed on the receiving side of the controlled optical fibres. Power levels are taken as reference during installation. The power meter is connected to the OTDR controlling computer to form a complete monitoring unit. If the continuous power meter detects a slip from the reference, the OTDR is immediately directed to the fibre for testing. This eliminates the time gap that occurs in case of an unfavourable switching order [19-23].

## FAULTS AND CHARACTERISTICS OF OPTICAL NETWORKS

There are various approaches to classifying the faults in optical networks. However, in our case, the most important type of error is increased line attenuation. The maximum power emitted by the transmitter does not reach the receiver unit at the proper level due to the increase in attenuation. Negative changes in attenuation are possible due to:

- change in fibre characteristics,
- degradation of connectors,
- changes in transmitter power and receiver sensitivity

### CHANGE IN FIBRE CHARACTERISTICS

The attenuation of optical fibres may vary mainly due to the physical effects on them.

Material structural stresses are induced due to the twisting and shear forces on the cable. These stresses create inhomogeneous sections in the fibres, which result in local attenuation sites.

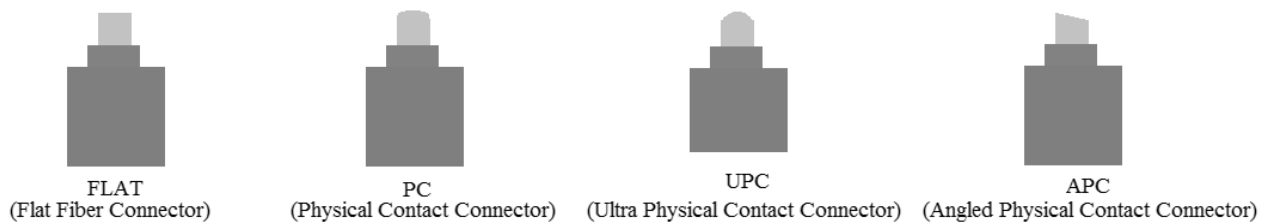
Another typical defect is the exposure of the cables – and thus the fibres – to high fibre tensile forces. This effect also leads to material structure issues. If a fibre-optic cable and its fibres are damaged by longitudinal contact, the entire section may become unusable [24].

Transverse rupture of the fibres may occur during construction, e.g. being cut through by a machine. Of course, this leads to a complete rupture, which can be repaired by fibre welding or section replacement.

Improper cable routing can also result in an increase in attenuation by breaking below the smallest bend radius. In this case, if the fibres do not suffer permanent damage, the attenuation resets to its original state once the error is eliminated. These errors are called macrobanding errors.

## DEGRADATION OF CONNECTORS

Each optical system connects to network components using connectors. These connectors vary by cable types. Typically, faults in connectors can be traced back to mechanical faults and/or issues caused by dirt getting into the network. The fibre ends in the connectors can be flat, rounded (PC, UPC), or bevelled (APC), Figure 15.



**Figure 15.** Connector types.

The alignment of the connectors greatly determines the attenuation value. If a centrality error or large air gap develops, the refractive index changes between the two photoconductor cores, and causes unwanted attenuation in the transmission path.

Furthermore, it must be ensured that the connection of the connectors is uncontaminated, as attenuation error occurs when contaminants go between the contact surfaces [30, 32, 33].

## CHANGES IN TRANSMITTER PERFORMANCE AND RECEIVER SENSITIVITY

In this case, the error occurs on a device that is not dependent on the attenuation of the optical network in question. This type of error means damage to the terminal equipment, which can be solved by replacing or repairing the units [25, 28].

## OTHER DEFECTS THAT CAN BE DETECTED BY THE OPTICAL FIBRE MONITORING SYSTEM

In addition to the errors listed above, optical fibre monitoring can detect slow or intermittent attenuation errors. This means that an alarm threshold is set as a reference value for the entire line segment taken during the installation of the monitoring system. When the controlled fibre attenuation reaches the set value of  $-3$  dB difference threshold, the control panel generates an alarm.

Continuous thread monitoring can also detect errors that are difficult to detect with other intermittent OTDR solutions. If the error does not occur for most of the time or the fibre

parameter does not deviate significantly from the reference value, then there are only brief moments when the attenuation increases somewhere in the fibre.

Such an error may be a mechanically unstable connector which, when periodically moved, results in a significant attenuation or intermittent breakage of the optical fibre when it is, for example, pinched by or pushed up against some parts of the rack cabinet.

Such continuous fibre monitoring equipment is also an essential means of protecting optical fibres from an information security point of view. Attempt to intercept optical fibres may be accompanied by an attenuation error that requires branching or bending. The resulting attenuation may also be detectable. If the alert threshold for monitoring is sufficiently sensitive, then the appearance of a small amount of attenuation can be immediately and automatically detected [31].

## **SUMMARY**

The subject of the present article is one of the fastest-growing, but also quite challenging technical solutions for data transfer in smart cities. The fibre-optic used in light communication has been overcoming its limitations and disadvantages since its first appearance. Because of its advantages, this technology is an essential physical layer of info-communication in rooms protected from the point of information security. The study presented in this paper summarizes the principles related to the measurement of optical fibre attenuation. It describes the measurement of the backscatter attenuation and the measurement methods that can be implemented with OTDR. It then examines the potentials and characteristics of optical networks. The research and its summary have a great importance, as the technology and the monitoring system in question are slowly taking over the role of the physical layer of longer-range info-communication devices, making a significant leap in the quality parameters of telecommunications. Comparing the theses of the research with the above findings, the correctness of the theses can be logically deduced.

## **REFERENCES**

- [1] Cebe, L.: *Fénytvázközlés*.  
Kandó Kálmán Műszaki Főiskola, Budapest, 1990,
- [2] Smigura, L.: *Távközlő kábelek és vezetékek*.  
Magyar Posta Könyvkiadó, Budapest, 1989,
- [3] Jutasi, I.; Vámos, P.; Márkus, E.; Tarnay, K. and Nádorfí, Gy.: *Fényvezető távközlési rendszer tervezése (CCITT)*.  
Távközlési Könyvkiadó, Budapest, 1991,
- [4] Gyárfás, A.: *Optikai elemek mérése EDUCOPTIC mérőberendezéssel*.  
Budapesti Műszaki Főiskola Kandó Kálmán Villamosmérnöki Főiskolai Kar, Budapest, 174/1997, 2006,
- [5] Gárfás, A.: *Optikai szálak mérése OTDR-rel*.  
Kandó Kálmán Műszaki Főiskola, Budapest, 176/197, 1997,
- [6] Lajtha, Gy. and Szép, I.: *Fénytvázközlő rendszerek és elemeik*.  
Akadémiai Kiadó, Budapest, 1987,
- [7] Ákos, Gy.; Jani, P. and Varró, S., eds.: *Lézerek tudományos és gyakorlati alkalmazása*.  
Prosperitas Kft., Budapest, 1993,
- [8] Antók, P. I.: *Fényvezető Kábelhálózat Építése*.  
Vonalas füzet, Mackensen Kft., Budapest, 2009,
- [9] Elek, A.: *Nyomvonalas távközlési hálózatépítési technológiák kézikönyve*.  
Magyar Elektronikai és Infokommunikációs Szövetség, Budapest, 2006,
- [10] Antók, P.I.: *Fényvezető Hálózatok Gyakorlat 2. Passzív és aktív elemek a gyakorlatban*.  
Budakalász, 2011,

- [11] Antók, P.I.: *Fényvezető Hálózatok II. Fényvezető hálózat alapismeret*, Antók Mérnöki Iroda Kft., Budapest, 2011,
- [12] Antók, P.I.: *Fényvezető Hálózatok VI., Fényvezető hálózatok létesítése II.* Antók Mérnöki Iroda Kft., Budapest, 2011,
- [13] Antók, P.I.: *Fényvezető Hálózatok VIII., Fényvezető hálózatok tervezése II.* Antók Mérnöki Iroda Kft., Budapest, 2011,
- [14] Antók, P.I.: *Fényvezető Hálózatok IX. Szélessávú Optikai Hálózat Tervezése, Méretezés.* Antók Mérnöki Iroda Kft., Budapest, 2011,
- [15] Choquet, L.: *Reference Guide to Fiber Optic Testing, Glossary.* JDSU Corporation, 2008,
- [16] Laferrière, J.; Lietaert, G.; Taws, R. and Wolszczak, S.: *Reference Guide to Fiber Optic Testing.* Vol. 1. JDSU Corporation, 2007,
- [17] Collings, B.; Heismann, F. and Lietaert, G.: *Reference Guide to Fiber Optic Testing.* Vol. 2. JDSU Corporation, 2010,
- [18] NTest Inc.: *User Guide: NTest FiberWatch RFTS System-0904.*
- [19] Fiber Optics For Sale Co.: *Fiber Optic Cable Tutorial.* <http://www.fiberoptics4sale.com/Merchant2/fiber-optic-cable.php>, accessed September 2018,
- [20] Mediadot Kft.: *Optikai kábelek, Sommerkábel.* <http://www.sommerkabel.hu/optikai-kabelek-leiras.html>, accessed October 2018,
- [21] NTest Inc.: *Dark Fiber Monitoring.* <http://www.ntestinc.com/darkfiber.html>, accessed September 2018,
- [22] EXFO Inc.: *Live Fiber Monitoring in CWDM Networks, Olivier Plomteux, Senior Product Line Manager, Optical Business Unit.* [http://www.ccontrols.ch/cms/upload/downloads/Telecom/1206EN\\_FiberGuardianApplicationNote\\_LiveFiberMonitoringCWDM.pdf](http://www.ccontrols.ch/cms/upload/downloads/Telecom/1206EN_FiberGuardianApplicationNote_LiveFiberMonitoringCWDM.pdf), accessed September 2018,
- [23] Kozischek, D. and Bolick, M.: *Planning Link-Loss Budgets Using Statistics, Broadband Propertier.* [http://www.broadbandproperties.com/2007issues/jun07issues/corning\\_june.pdf](http://www.broadbandproperties.com/2007issues/jun07issues/corning_june.pdf), accessed July 2018,
- [24] *Optical Components: Light Amplifiers.* [http://ftp.utcluj.ro/pub/users/cemil/dwdm/dwdm\\_Intro/8\\_5311715.pdf](http://ftp.utcluj.ro/pub/users/cemil/dwdm/dwdm_Intro/8_5311715.pdf), accessed September 2018,
- [25] Atcom Services, Inc.: *Fiber Optic Cable.* <http://www.lanshack.com/fiber-optic-tutorial-cable.aspx>, accessed August 2018,
- [26] 3M: *3M™ Planar Light Circuit (PLC) Optical Splitters.* <http://multimedia.3m.com/mws/mediawebserver?66666UuZjcFSLXTtmxfcOXM6EVuQEcuZgVs6EVs6E666666-->, accessed October 2018,
- [27] The Telecommunications Industry Association: *Standard: TIA/EIA Standard; Commercial Building Telecommunications Cabling Standard; April 12. 2001.* <http://www.nag.ru/goodies/tia/TIA-EIA-568-B.1.pdf>, accessed May 2018,
- [28] Triple Play: *Fibre Formulas made simple.* <http://www.tripleplay.co.za/uploads/Optical%20Fibre%20Formulas.pdf>, accessed October 2018,
- [29] NTest Inc.: *Active Fiber Monitoring.* <http://www.ntestinc.com/activefiber.html>, accessed October 2018,
- [30] Pieter, N.J.M.J., et al.: *Small Bandwidth OTDR.* [http://www.nikhef.nl/~jelle/antareswebdocuments/Sb\\_otdr/SB-OTDR.pdf](http://www.nikhef.nl/~jelle/antareswebdocuments/Sb_otdr/SB-OTDR.pdf), accessed May 2018,
- [31] EXFO Inc.: *Live Fiber Monitoring in CWDM Networks—Part 2.* <http://www.exfo.com/corporate/blog/2010/live-fiber-monitoring-cwdm-networks-part-2>, accessed September 2018,
- [32] Varghese, S.; Priyamvada, M.; Mathew, M.; Swarish, N. and Suresh, N.: *A novel real-time Remote Fiber Monitoring System NeST Research & Development Centre.* <http://een.iust.ac.ir/profs/Sadr/Papers/netp9.pdf>, accessed October 2018,

- [33] Hell, P.M.; Varga, P.J. and Illési, Zs.: *Mobile Phones Thermo-Ergonomic Analysis*.  
In: *2018 IEEE 16th International Symposium on Intelligent Systems and Informatics*. IEEE,  
Subotica, 2018.